

1. TABLE FRAMES

with UP/DOWN
keys only (without
memory keys)



E-SMART 2M2S TQD

Electrical height adjustable desk frame



- ✓ 2 motors / 2 segments
- ✓ Handset with UP/DOWN keys
- ✓ Anti collision function



5 years warranty



Details

Frame

Anti-Collision
 Dynamic load: bis 80 kg
 Static load: bis 100 kg
 Speed: 32 mm/s
 Sound level: <42 dB
 Stroke: 700-1180 mm
 Frame width: 770-1400 mm
 Table-top size min.: 600x800 mm
 Table-top size max.: 800x1600 mm

Electrical Components / Handset

Input Voltage: 100 - 240 V, 50/60 Hz
 built-in load limit switch
 Duty cycle: 10 %, max. 2 min on,
 18 min off
 Power consumption: 52 W max
 0.2 W in Standby-mode



Technical Drawings

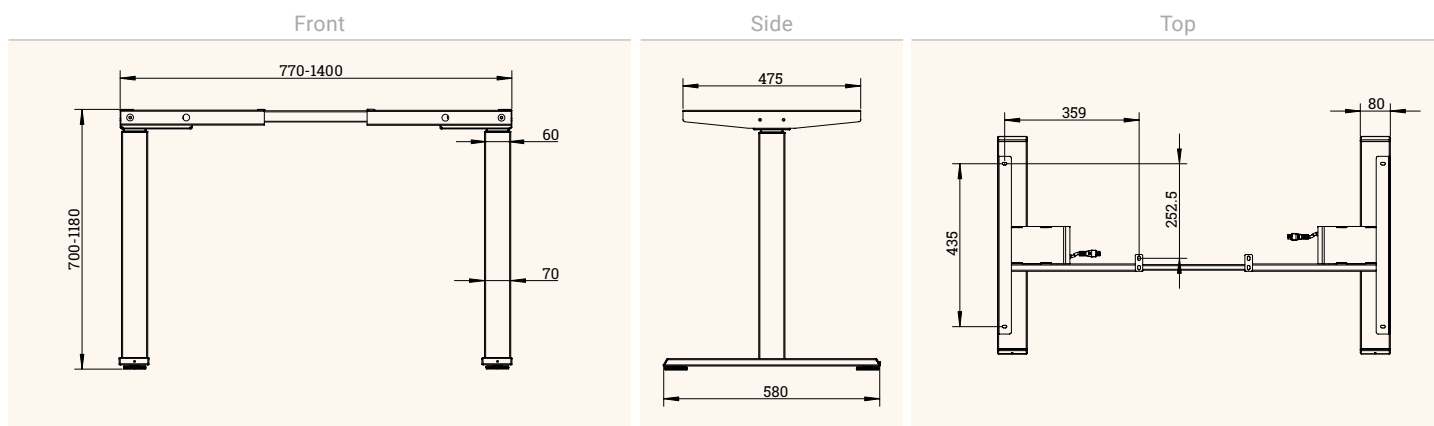

Article	Description	Colour	Item No.
E-SMART 2M2S TQD	Electrical height adjustable desk frame, 2 motors, 2 segments, square lifting columns	similar white aluminium, RAL 9006	301 127818
E-SMART 2M2S TQD	Electrical height adjustable desk frame, 2 motors, 2 segments, square lifting columns	similar pure white, RAL 9010	301 127832
E-SMART 2M2S TQD	Electrical height adjustable desk frame, 2 motors, 2 segments, square lifting columns	similar jet black, RAL 9005	301 127825



E-SMART 2M3S TQD

Electrical height adjustable desk frame



- ✓ 2 motors / 3 segments
- ✓ Handset with UP/DOWN keys
- ✓ Anti collision function



5 years warranty



Details

Frame

Anti-Collision	
Dynamic load:	bis 80 kg
Static load:	bis 100 kg
Speed:	32 mm/s
Sound level:	<42 dB
Stroke:	550-1210 mm
Frame width:	770-1400 mm
Table-top size min.:	500x800 mm
Table-top size max.:	800x1600 mm

Electrical Components / Handset

Input Voltage:	100 - 240 V, 50/60 Hz
	built-in load limit switch
Duty cycle:	10 %, max. 2 min on, 18 min off
Power consumption:	52 W max 0.2 W in Standby-mode



Technical Drawings

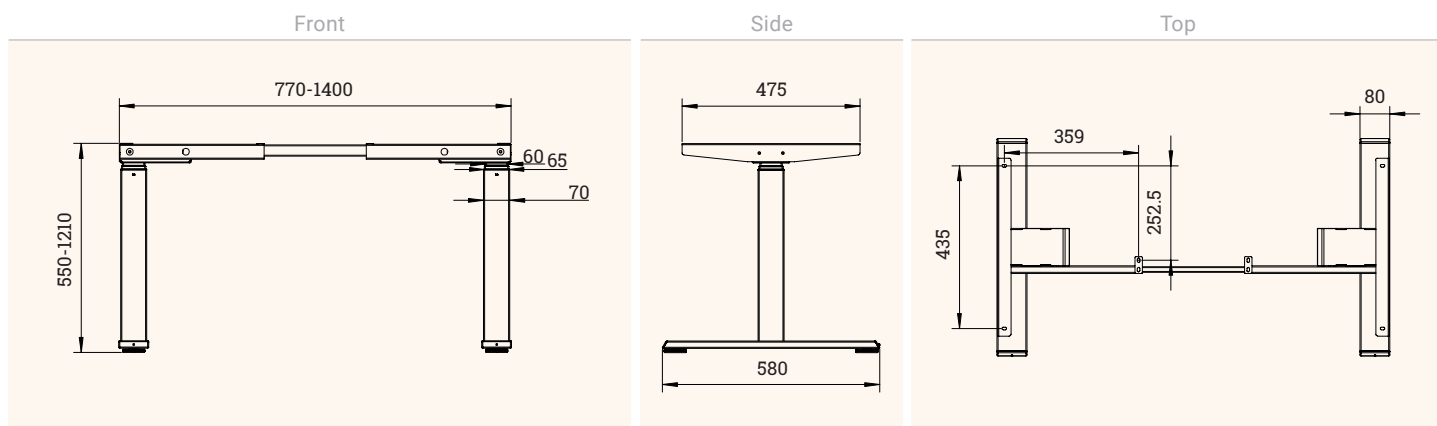

Article	Description	Colour	Item No.
E-SMART 2M3S TQD	Electrical height adjustable desk frame, 2 motors, 3 segments, square lifting columns	similar white aluminium, RAL 9006	301 128294
E-SMART 2M3S TQD	Electrical height adjustable desk frame, 2 motors, 3 segments, square lifting columns	similar pure white, RAL 9010	301 128308
E-SMART 2M3S TQD	Electrical height adjustable desk frame, 2 motors, 3 segments, square lifting columns	similar jet black, RAL 9005	301 128301

