

E-MORE 1M2S

Electrical height adjustable desk frame

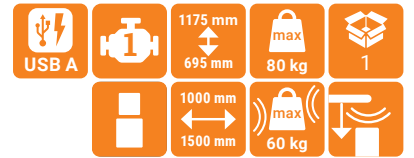

- ✓ 1 motor / 2 segments
- ✓ Handset with integrated USB-charging function
- ✓ 4 memory keys
- ✓ Anti collision function



5 years warranty



Details

Frame

Anti-Collision:	
Dynamic load:	60 kg max
Static load:	80 kg max
Speed:	25 mm/s
Sound level:	<50 db
Stroke:	695 – 1175 mm
Frame width:	1000 – 1500 mm
Table-top size min.:	600 x 1000 mm
Table-top size max.:	1000 x 1800 mm

Electrical Components / Handset

Input Voltage:	100 – 240 V
	built-in load limit switch
Duty cycle:	10 % max. 2 min on, 18 min off
Low energy consumpt.:	automatic power off
Display:	digital
Memory keys:	4



Technical Drawings

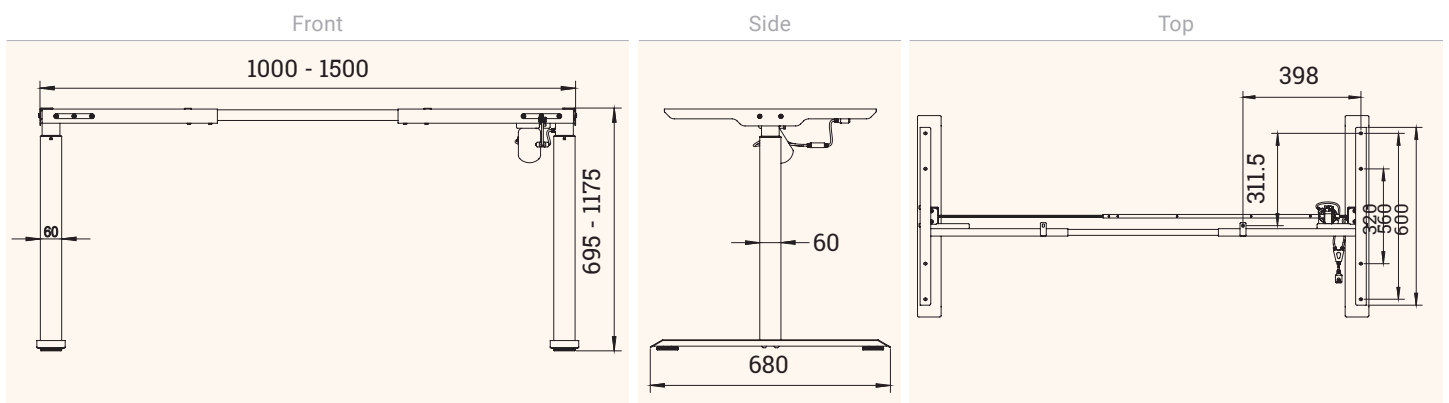

Article	Description	Colour	Item No.
E-MORE 1M2S	Electrical height adjustable desk frame, 1 motor, 2 segments, #4888.181	similar White aluminium, RAL 9006	301 109261
E-MORE 1M2S	Electrical height adjustable desk frame, 1 motor, 2 segments, #4888.182	similar Pure white, RAL 9010	301 121294
E-MORE 1M2S	Electrical height adjustable desk frame, 1 motor, 2 segments, #4888.183	similar Traffic black, RAL 9017	301 121301



E-MORE 2M2S

Electrical height adjustable desk frame



- ✓ 2 Motors / 2 segments
- ✓ Handset with integrated USB-charging function
- ✓ 4 memory keys
- ✓ Anti collision function



Details

Frame

Anti-Collision
 Built-in load limit switch
 Dynamic load: 100 kg max
 Static load: 120 kg max
 Speed: 32 mm/s
 Sound level: <42 db
 Stroke: 695 – 1145 mm
 Frame width: 1100 – 1800 mm
 Table-top size min.: 600 x 1100 mm
 Table-top size max.: 1000 x 2200 mm

Electrical Components / Handset

Input Voltage: 100 – 240 V, built-in load limit switch
 Duty cycle: 10 % max. 2 min on, 18 min off
 Low energy consumpt.: automatic power off
 Display: digital
 Memory keys: 4
 USB charging function: rear of handset
 5 W



Technical Drawings

Front

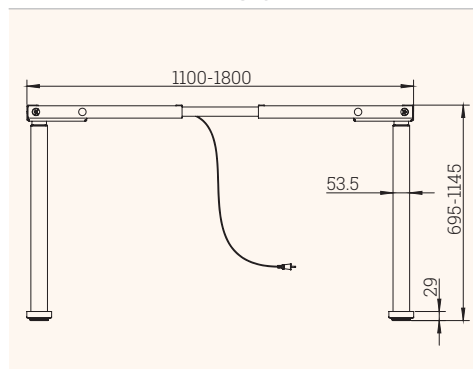

Side

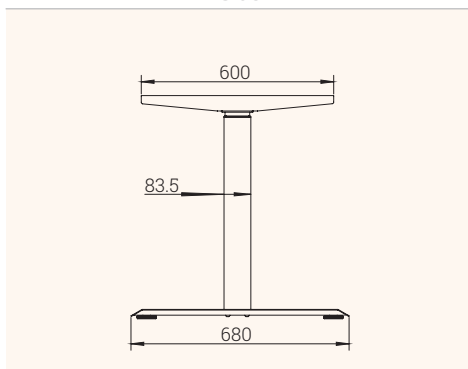

Top

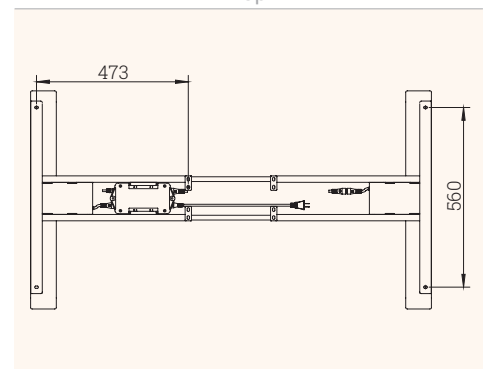

Article	Description	Colour	Item No.
E-MORE 2M2S	Electrical height adjustable desk frame, 2 motors, 2 segments, #4888.121	similar White aluminium, RAL 9006	301 109219
E-MORE 2M2S	Electrical height adjustable desk frame, 2 motors, 2 segments, #4888.122	similar Pure white, RAL 9010	301 109247
E-MORE 2M2S	Electrical height adjustable desk frame, 2 motors, 2 segments, #4888.123	similar Traffic black, RAL 9017	301 109254
BOXIT E-MORE	Cable canal, optional accessory for the table-frame	similar White aluminium, RAL 9006	203 108904
BOXIT E-MORE	Cable canal, optional accessory for the table-frame	similar Pure white, RAL 9010	203 108911
BOXIT E-MORE	Cable canal, optional accessory for the table-frame	similar Traffic black, RAL 9017	203108918



E-MORE 2M2S TQD

2-Segment electrical height adjustable desk frame



- ✓ 2 Motors / 2 segments
- ✓ Handset with LED
- ✓ 3 memory keys
- ✓ Anti collision function

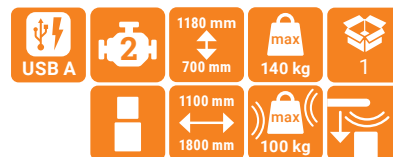

5 years warranty



Details

Frame

Anti-Collision
 Dynamic load: 100 kg max
 Static load: 140 kg max
 Speed: 30 mm/s
 Sound level: <45 db
 Stroke: 700 – 1180 mm
 Frame width: 1100 – 1800 mm
 Table-top size min.: 600 x 1100 mm
 Table-top size max.: 1000 x 2200 mm

Electrical Components / Handset

Input Voltage: 100 – 240 V, built-in load limit switch
 Duty cycle: 10 % max. 2 min on, 18 min off
 Low energy consumption: automatic power off
 Display: digital
 Memory keys: 3
 USB charging function: bottom of handset
 10 W



Technical Drawings

Front

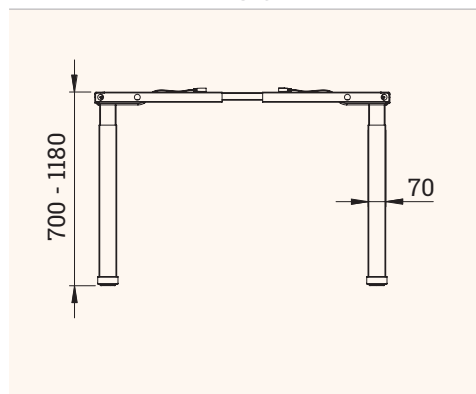

Side

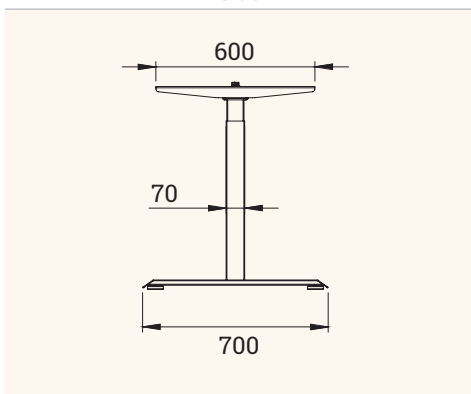

Top

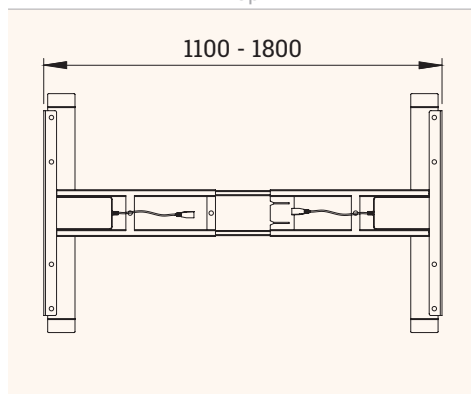

Article	Description	Colour	Item No.
E-MORE 2M2S TQD	Electrical height adjustable desk frame, 2 motors, 2 segments, square lifting columns	similar White aluminium, RAL 9006	301 123303
E-MORE 2M2S TQD	Electrical height adjustable desk frame, 2 motors, 2 segments, square lifting columns	similar Traffic white, RAL 9016	301 123296
E-MORE 2M2S TQD	Electrical height adjustable desk frame, 2 motors, 2 segments, square lifting columns	similar Jet black, RAL 9005	301 123289



E-MORE 2M3S

Electrical height adjustable desk frame



- ✓ 2 motors / 3 segments
- ✓ Handset with integrated USB-charging function
- ✓ 4 memory keys
- ✓ Anti collision function

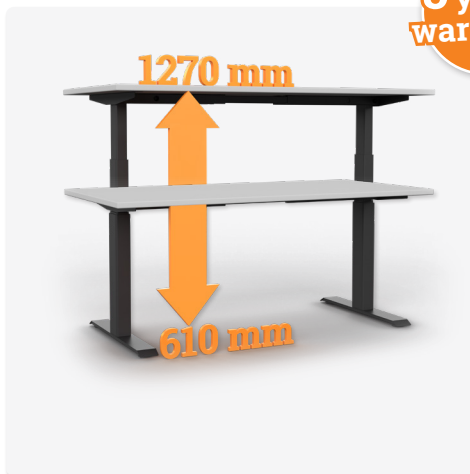
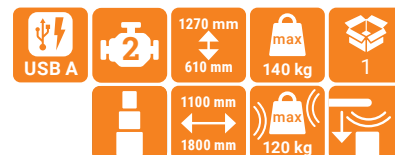

5 years warranty



Details

Frame

Anti-Collision
 Built-in load limit switch
 Dynamic load: 120 kg max
 Static load: 140 kg max
 Speed: 40 mm/s
 Sound level: <42 db
 Stroke: 610-1270 mm
 Frame width: 1100-1800 mm
 Table-top size min.: 600x1100 mm
 Table-top size max.: 1000x2200 mm

Electrical Components / Handset

Input Voltage: 100 – 240 V, built-in load limit switch
 Duty cycle: 10 % max. 2 min on, 18 min off
 Low energy consumpt.: automatic power off
 Display: digital
 Memory keys: 4
 USB charging function: rear of handset
 5 W



Technical Drawings

Front

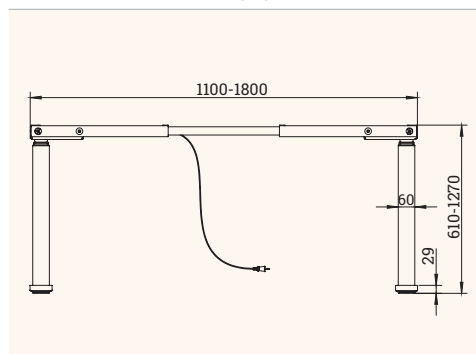

Side

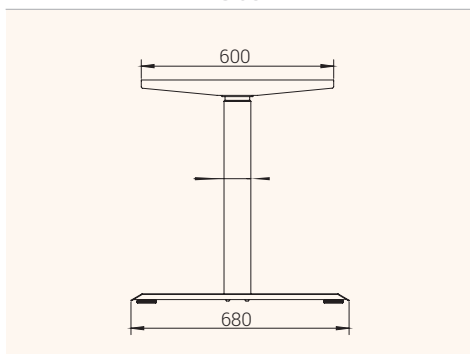

Top

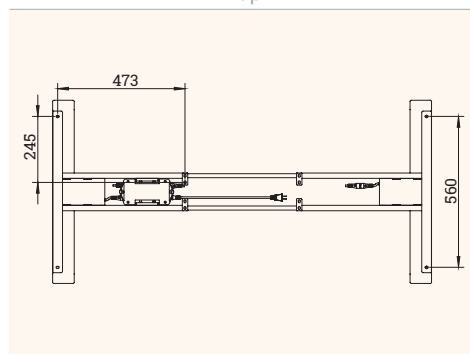

Article	Description	Colour	Item No.
E-MORE 2M3S	Electrical height adjustable desk frame, 2 motors, 3 segments, #4888.111	similar White aluminium, RAL 9006	301 109198
E-MORE 2M3S	Electrical height adjustable desk frame, 2 motors, 3 segments, #4888.112	similar Pure white, RAL 9010	301 109205
E-MORE 2M3S	Electrical height adjustable desk frame, 2 motors, 3 segments, #4888.113	similar Traffic black, RAL 9017	301 109212
BOXIT E-MORE	Cable canal, optional accessory for the table-frame	similar White aluminium, RAL 9006	203 108904
BOXIT E-MORE	Cable canal, optional accessory for the table-frame	pure white, RAL 9010	203 108911
BOXIT E-MORE	Cable canal, optional accessory for the table-frame	traffic black, RAL 9017	203108918



E-MORE 2M3S TQD

3-Segment electrical height adjustable desk frame



- ✓ 2 Motors / 3 segments
- ✓ Handset with LED
- ✓ 3 memory keys
- ✓ Anti collision function



5 years warranty



Details

Frame

Anti-Collision
 Dynamic load: 120 kg max
 Static load: 160 kg max
 Speed: 38 mm/s
 Sound level: <45 db
 Stroke: 600-1250 mm
 Frame width: 1100-1800 mm
 Table-top size min.: 600x1100 mm
 Table-top size max.: 1000x2200 mm

Electrical Components / Handset

Input Voltage: 100 – 240 V
 built-in load limit switch
 Duty cycle: 10 % max. 2 min on, 18 min off
 Low energy consumpt.: automatic power off
 Display: digital
 Memory keys: 3
 USB charging function: bottom of handset
 10 W



Technical Drawings

Front

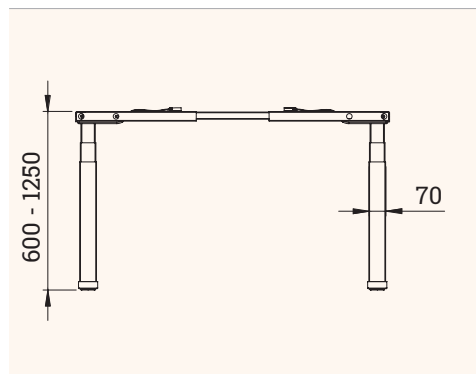

Side

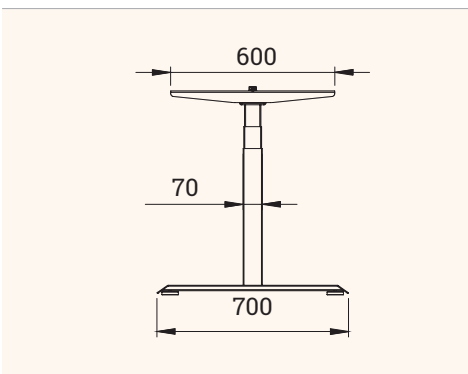

Top

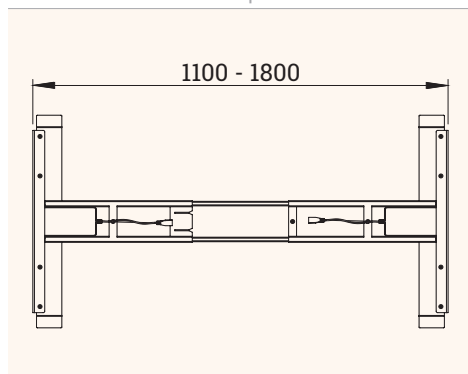

Article	Description	Colour	Item No.
E-MORE 2M3S TQD	Electrical height adjustable desk frame, 2 motors, 3 segments, square lifting columns	similar White aluminium, RAL 9006	301 123268
E-MORE 2M3S TQD	Electrical height adjustable desk frame, 2 motors, 3 segments, square lifting columns	similar Traffic white, RAL 9016	301 123282
E-MORE 2M3S TQD	Electrical height adjustable desk frame, 2 motors, 3 segments, square lifting columns	similar Jet black, RAL 9005	301 123275



E-CORNER 90

Electrical height adjustable desk frame



- ✓ 3 Motors / 3 segments
- ✓ Handset with integrated USB-charging function
- ✓ 4 memory keys
- ✓ Anti collision function



5 years warranty

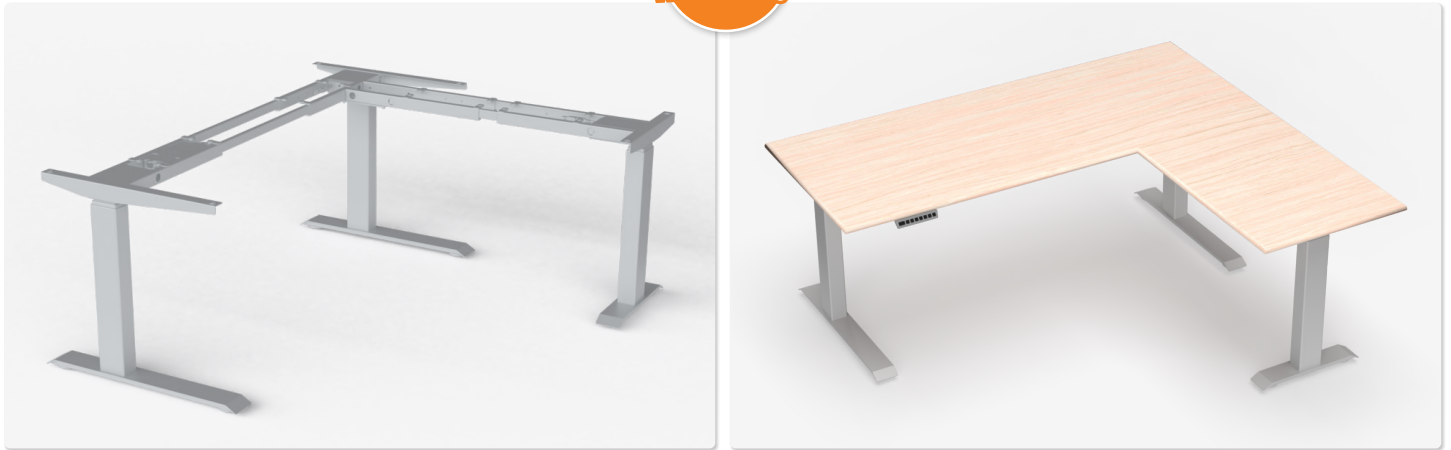

Details

Frame

Anti-Collision Built-in load limit switch
 Dynamic load: 160 kg max
 Static load: 180 kg max
 Speed: 30 mm/s
 Sound level: <42 db
 Stroke: 610 – 1270 mm
 Frame width: 1100 – 1800 mm
 Table top size min.:
 ① 700x1000 mm
 ② 400x1278 mm
 Table top size max.:
 ① 1000x1800 mm
 ② 1000x2048 mm

Electrical Components / Handset

Input Voltage: 100 – 240 V
 built-in load limit switch
 Duty cycle: 10 % max. 2 min on, 18 min off
 Low energy consumpt.: automatic power off
 Display: digital
 Memory keys: 4
 USB charging function: rear of handset
 5 W



Technical Drawings

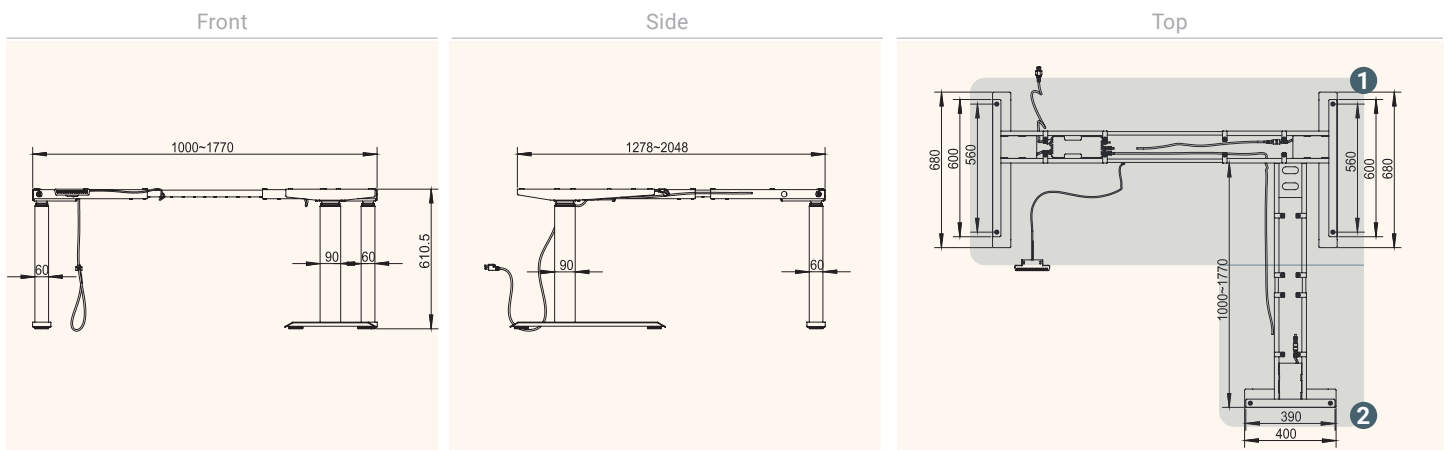

Article	Description	Colour	Item No.
E-CORNER 90	Electrical height adjustable desk frame, 3 motors, 3 segments, #4888.111	similar White aluminium, RAL 9006	301 122512
E-CORNER 90	Electrical height adjustable desk frame, 3 motors, 3 segments, #4888.112	similar Pure white, RAL 9010	301 122519
E-CORNER 90	Electrical height adjustable desk frame, 3 motors, 3 segments, #4888.113	similar Traffic black, RAL 9017	301 122526
BOXIT E-MORE	Cable canal, optional accessory for the table-frame	similar White aluminium, RAL 9006	203 108904
BOXIT E-MORE	Cable canal, optional accessory for the table-frame	similar Pure white, RAL 9010	203 108911
BOXIT E-MORE	Cable canal, optional accessory for the table-frame	similar Traffic black, RAL 9017	203108918



E-CORNER Flex TQD

Electrical height adjustable desk frame



- ✓ 3 Motors / 3 segments
- ✓ Handset with LED
- ✓ 3 memory keys
- ✓ Anti collision function
- ✓ Table-frame is adjustable from 90° to 180°



5 years warranty



Details

Frame

Anti-Collision	
Dynamic load:	160 kg max
Static load:	180 kg max
Speed:	30 mm/s
Sound level:	<45 db
Stroke:	600-1250 mm
Frame width:	1100-1800 mm
Frame width on 180°:	2200-3700 mm
Table top size min.:	<ol style="list-style-type: none"> 600x1500 mm 600x1400 mm 600x2300 mm
Table top size max.:	<ol style="list-style-type: none"> 1000x2200 mm 1000x2100 mm 1000x4000 mm

Electrical Components / Handset

Input Voltage:	220 – 240 V
	built-in load limit switch
Duty cycle:	10 % max. 2 min on, 18 min off
Low energy consumpt.:	automatic power off
Display:	digital
Memory keys:	3
USB charging function:	bottom of handset
	10 W



Technical Drawings

Side / 3D View

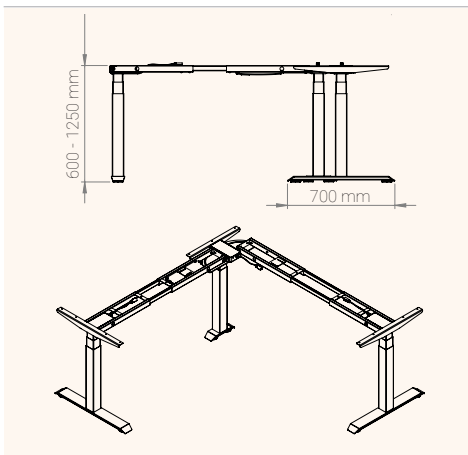

180°

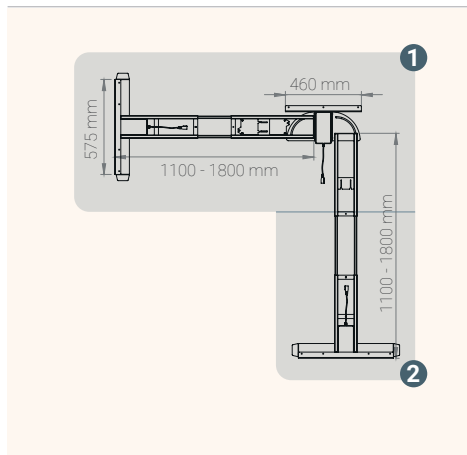

90°

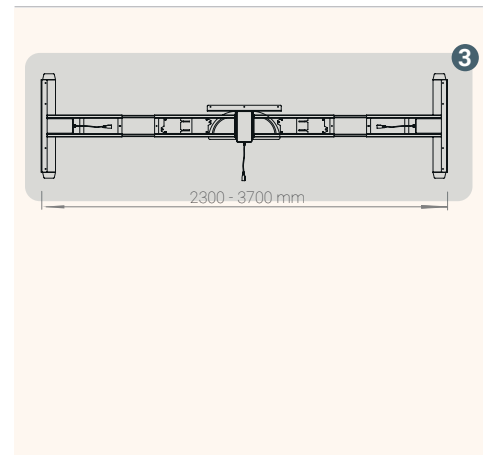

Article	Description	Colour	Item No.
E-CORNER Flex TQD	Electrical height adjustable desk frame, 3 motors, 3 segments, #4888.111	similar White aluminium, RAL 9006	301 123464
E-CORNER Flex TQD	Electrical height adjustable desk frame, 3 motors, 3 segments, #4888.112	similar Traffic white, RAL 9016	301 123478
E-CORNER Flex TQD	Electrical height adjustable desk frame, 3 motors, 3 segments, #4888.113	similar Jet black, RAL 9005	301 123471



E-MORE Move

Electrical height adjustable and rollable desk frame



- ✓ Movable on two casters
- ✓ 1 motor / 2-segments
- ✓ Hand control with LED display
- ✓ 4 memory keys
- ✓ Anti collision function



5 years warranty



Details

Frame

Anti-Collision
 Dynamic load: 80 kg max
 Static load: 100 kg max
 Speed: 30 mm/s
 Sound level: <50 db
 Stroke: 680 - 1130 mm
 Frame width: 1100 - 1600 mm
 Table-top size min.: 600 x 1100 mm
 Table-top size max.: 1000 x 2000 mm

Electrical Components / Handset

Input Voltage: 100 - 240 V (built-in load limit switch)
 Duty cycle: 10 % max. 2 min on, 18 min off
 Low energy consumpt.: automatic power off
 Display: digital
 Memory keys: 4
 Switch power supply



Technical Drawings

Front

Side

Top

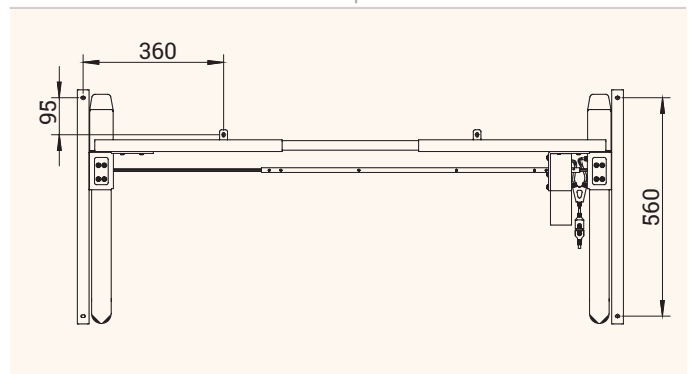
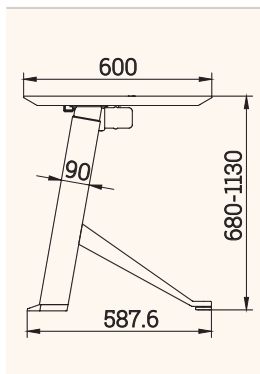
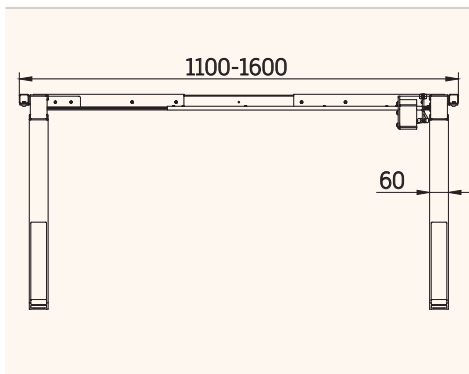

Article	Description	Colour	Item No.
E-MORE Move	Electrical height adjustable desk frame, 2 motors, 2 segments, movable, #4888.141	similar White aluminium, RAL 9006	301 109289
E-MORE Move	Electrical height adjustable desk frame, 2 motors, 2 segments, movable, #4888.142	similar Pure white, RAL 9010	301 108848
E-MORE Move	Electrical height adjustable desk frame, 2 motors, 2 segments, movable, #4888.143	similar Traffic black, RAL 9017	301 108855



E-MORE Overview

All our height adjustable E-MORE Table-frames at a glance



The **E-MORE** Table-frames are very versatile and can be used in many different home or work situations. Because of their height adjustable feature, they can change from standing table to a table with the perfect sitting height in a matter of seconds.



Model name	E-MORE 1M2S	E-MORE 2M2S	E-MORE 2M2S TQD	E-MORE 2M3S	E-MORE 2M3S TQD	E-CORNER 90	E-CORNER Flex TQD	E-MORE Move
Motors	1	2	2	2	2	3	3	1
Segments	2	2	2	3	3	3	3	2
Cross-section lifting columns	60x60	53,5x83,5	70x70	60x90	70x70	60x90	70x70	60x90
Frame width (mm)	1000-1500	1100-1800			1278-2048 1000-1770		1100-1800 1100-1800	1100-1600
Table top size min. (mm)	600x1000	600x1100			<ol style="list-style-type: none"> 700x1000 400x1278 		<ol style="list-style-type: none"> 600x1500 600x1400 600x2300 	600x1100
Table top size max (mm)	1000x1800	1000x2200			<ol style="list-style-type: none"> 1000x1800 1000x2048 		<ol style="list-style-type: none"> 1000x2200 1000x2100 1000x4000 	1000x2000
Lifting range (mm)	695-1175	695-1155	700-1180	610-1270	600-1250	610-1270	600 - 1250	680-1130
Speed (mm/s)	25	32	30	40	38	30	30	30
Load capacity static (kg)	80	120	140	140	160	180	180	100
Load capacity dynamic (kg)	60	100	100	120	120	160	160	80
Sound level (db)	<50	<42	<45	<42	<45	<42	<45	<50
Digital Handset	✔	✔	✔	✔	✔	✔	✔	✔
Memory keys	4	4	3	4	3	4	3	4
USB-A-Charging (W)	-	5	10	5	10	5	10	-
Power consumption in standby (W)	0,20	0,20	2,00	0,20	2,00	2,00	2,00	0,20
Max. Power consumpt. in work (W)	150	130	120	130	120	300	320	150
Article numbers (white)	301 121294	301 109247	301 123296	301 109205	301 123282	301 122519	301 123478	301 108848
Article numbers (silver)	301 109261	301 109219	301 123303	301 109198	301 123268	301 122512	301 123464	301 109289
Article numbers (black)	301 121301	301 109254	301 123289	301 109212	301 123275	301 122526	301 123471	301 108855





similar RAL 9010, Pure white



similar RAL 9016, Traffic white



similar RAL 9006, White aluminium



similar RAL 9017, Traffic black



similar RAL 9005, Jet black